

# SPARK SERIES

**POWERFUL JUMPERS**

So far unsurpassed manual compaction machines of small dimensions, which, thanks to the high compacting force, are able to affect the material at great depth.

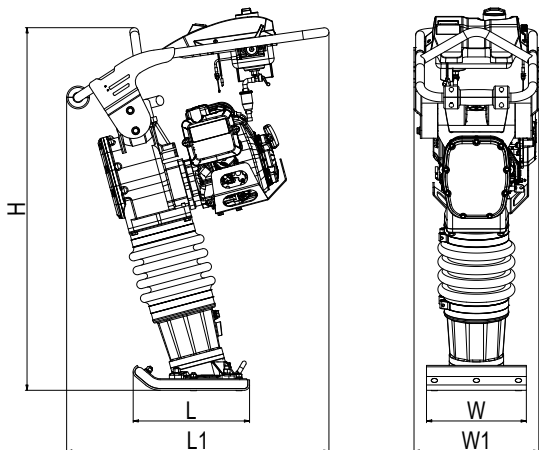



TYPE	Machine dimensions (mm)				
	H	L	L1	W	W1
NT 64P	1050	350	790	250	355

## FEATURES

- Central lifting eye
- Handling wheels and handling handle
- Trottle lever
- High quality bellows
- Air prefilter

## TECHNICAL PARAMETERS

### OPERATIONAL PARAMETERS

Operational weight	[kg]	64
Shoe dimensions (W x L)	[mm]	250 x 300
Compacting force	[kN]	15
Frequency	[min <sup>-1</sup> ]	650
Amplitude	[mm]	55
Additional air filter	[-]	Yes

### ENGINE

Maker and type	Honda	GX 120
Fuel	[-]	Petrol
Net power ( 3600 r./min )	[kW]	2,7
Emission class	[-]	EU Stage V

### OPERATIONAL FLUIDS

Fuel tank capacity (petrol)	[l]	2,8
Engine oil capacity (10W30)	[l]	0,4
Gearbox oil capacity (10W30)	[l]	1

### HYGIENE PARAMETERS

Noise level L <sub>pA,d</sub>	[dB]	94+1
Noise level L <sub>WA,G</sub>	[dB]	109
Vibration a <sub>hvd</sub>	[m/s <sup>2</sup> ]	9,2+3,7

## OPTIONAL ACCESSORIES