

So far unsurpassed manual compaction machines of small dimensions, which, thanks to the high compacting force, are able to affect the material at great depth.

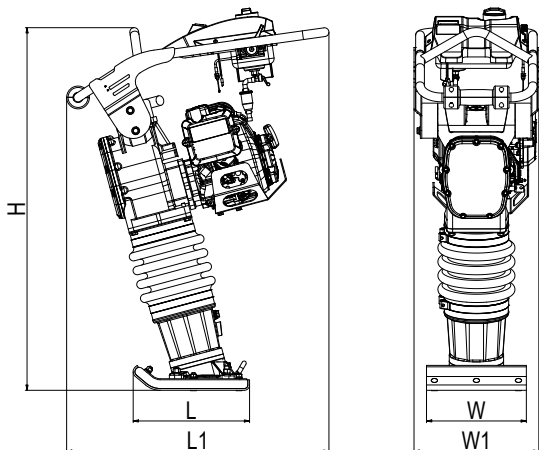



TYPE	Machine dimensions (mm)				
	H	L	L1	W	W1
NT 76P	1060	345	790	285	390

FEATURES
Central lifting eye
Handling wheels and handling handle
Trottle lever
High quality bellows

TECHNICAL PARAMETERS

OPERATIONAL PARAMETERS		
Operational weight	[kg]	76
Shoe dimensions (W x L)	[mm]	285 x 345
Compacting force	[kN]	18
Frequency	[Hz]	650
Amplitude	[mm]	70
Additional air filter	[-]	Yes

ENGINE		
Maker and type	Honda	GX 120
Fuel	[-]	Petrol
Net power (3600 r./min)	[kW]	2,7
Emission class	[-]	EU Stage V

OPERATIONAL FLUIDS		
Fuel tank capacity (petrol)	[l]	2,8
Engine oil capacity (10W30)	[l]	0,4
Gearbox oil capacity (10W30)	[l]	0,7

HYGIENE PARAMETERS		
Noise level $L_{pA,d}$	[dB]	94+1
Noise level $L_{WA,G}$	[dB]	106
Vibration a_{hvd}	[m/s ²]	9,2+3,7

OPTIONAL ACCESSORIES
Handle under the engine <input type="checkbox"/>