

# PRACTIC SERIES

THE CLEAR CHOICE FOR THE MOST DEMANDING

These forward vibratory plates respond to requirements of variability and offer a huge range of variations while maintain the highest quality of processing and work performance.

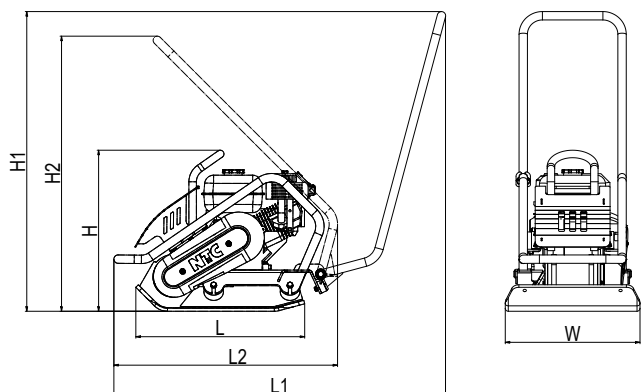



TYP	Machine dimensions (mm)						
VD 15P	H	H1	H2	L	L1	L2	W
	535	1000	920	565	1110	920	400

## FEATURES

- Frame design
- Folding handle
- Central lifting eye
- Two-staged vibration reduction
- Handling points on all sides of the machine
- Rounded edges of the plate

## TECHNICAL PARAMETERS

### OPERATIONAL PARAMETERS

Operational weight	[kg]	85
Plate dimensions (W x L)	[mm]	400 x 565
Centrifugal force	[kN]	15
Frequency	[Hz]	100
Maximal speed	[m/min]	25

### ENGINE

Maker and type	Honda	GX 160
Fuel	[-]	Petrol
Net power ( 3600 r./min )	[kW]	3,6
Emission class	[-]	EU Stage V

### OPERATIONAL FLUIDS

Fuel tank capacity (petrol)	[l]	3,1
Engine oil capacity (10W30)	[l]	0,6
Exciter oil capacity (10W30)	[l]	0,07

### HYGIENE PARAMETERS

Noise level $L_{pA,d}$	[dB]	91+4
Noise level $L_{wA,g}$	[dB]	105
Vibration $a_{hvd}$	[m/s <sup>2</sup> ]	8,4+3,4

## OPTIONAL ACCESSORIES

- Sprinkling kit (capacity of the tank 12 l)
- Soft pad for pavement compaction
- Wheel kit for easy handling
- Hour counter
- Trottle lever on the handle
- Roller plate