

# KLASIK SERIES

FOR UNRIVALED PERFORMANCE

These vibration plates keep the concept of "old school" machines, which stands for the highest durability and performance. Whole concept is designed to keep the promise of unbreakable machine.

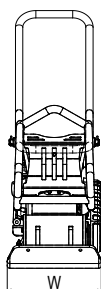

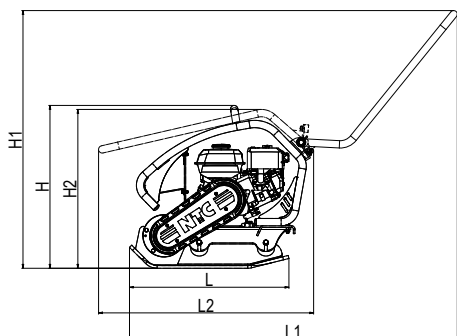

TYPE	Machine dimensions (mm)						
	H	H1	H2	L	L1	L2	W
VD 350/16	360	900	350	610	1300	830	350

## TECHNICAL PARAMETERS

### OPERATIONAL PARAMETERS

Operational weight	[kg]	105
Plate dimensions (W x L)	[mm]	350 x 610
Centrifugal force	[kN]	16
Frequency	[Hz]	81
Maximal speed	[m/min]	24

### ENGINE

Maker and type	Honda	GX 120
Fuel	[-]	Petrol
Net power ( 3600 r./min )	[kW]	2,6
Emission class	[-]	EU Stage V

### OPERATIONAL FLUIDS

Fuel tank capacity (petrol)	[l]	2
Engine oil capacity (10W30)	[l]	0,6
Exciter oil capacity (10W30)	[l]	0,1

### HYGIENE PARAMETERS

Noise level $L_{pA,d}$	[dB]	86+2
Noise level $L_{WA,G}$	[dB]	101
Vibration $a_{hvd}$	[m/s <sup>2</sup> ]	12,3+4,9

## FEATURES

- Frame design
- Folding handle
- Central lifting eye
- Two-staged vibration reduction
- Handling points on all sides of the machine
- Rounded edges of the plate

## OPTIONAL ACCESSORIES

- Sprinkling kit (capacity of the tank 5 l)
- Soft pad for pavement compaction
- Wheel kit for easy handling
- Hour counter
- Trottle lever on the handle