

DUTY SERIES

HEAVYWEIGHT PLATES 300 - 500 KG

The Duty series vibratory plates are presented as the most efficient machines in the category of vibratory plates. Thanks to optimized, interconnected parameters, they achieve the highest cumulative area performance in this category.



Lifting eye

Centrální závěsné oko pro snadnou manipulaci.

Throttle lever

Integrated to the handle.

Service points

Easy access to service points thanks to the service hatches.

Vibration reduction

Four-staged vibration reduction affords high working comfort without any limits of occupational exposure.

Drive control

Implemented to the handle.

Frame design

A high level of coverage ensures protection in the most demanding conditions.

Hydraulic system

Fully hydraulic control system with automatic venting and hydraulic circuit adjustment.

Resistant plate

Made of rolled steel.

Engine

Available with Honda GX series and Hatz B series.



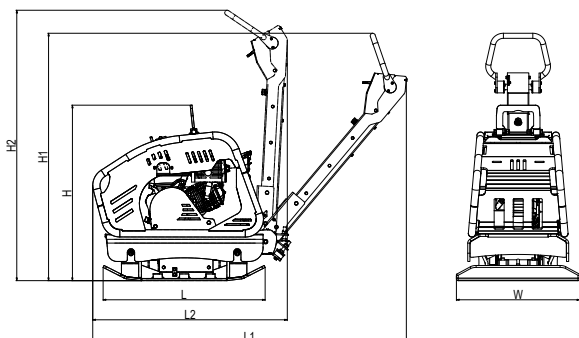

TYPE	Machine dimensions (mm)						
	H	H1	H2	L	L1	L2	W
VDR 52	940	1055	1400	815	1420	1150	600

TECHNICAL PARAMETERS		
HYGIENE PARAMETERS		
Noise level $L_{pA,d}$	[dB]	91+1
Noise level $L_{WA,G}$	[dB]	107
Vibration a_{hvd}	[m/s^2]	6,6+2,6

TECHNICAL PARAMETERS

OPERATIONAL PARAMETERS

Operational weight	[kg]	340
Plate dimensions (W x L)	[mm]	600 x 815
Centrifugal force	[kN]	52
Frequency	[Hz]	75
Amplitude	[mm]	2
Maximal speed	[m/min]	28
Electric start	[-]	No

FEATURES	
Frame design	
Folding handle	
Central lifting eye	
Three-staged vibration reduction	
Handling points on all sides of the machine	
Rounded edges of the plate	
Trottle lever on the handle	

ENGINE		
Maker and type	Honda	GX 270
Fuel	[-]	Petrol
Net power (3600 r./min)	[kW]	6,3
Emission class	[-]	EU Stage V

OPTIONAL ACCESSORIES	
Soft pad for high-load-paving compaction	<input type="checkbox"/>
Hour counter	<input type="checkbox"/>

OPERATIONAL FLUIDS		
Fuel tank capacity (petrol)	[l]	5,3
Engine oil capacity (10W30)	[l]	1,1
Hydraulic oil capacity (OH-HV 68)	[l]	0,28
Exciter oil capacity (10W30)	[l]	0,5